

---

PORTABLE RECORDER

U – 212A (00)

---

Instruction Manual

---

Read this instruction manual thoroughly before use.

PANTOS CO., LTD.  
KYOTO, JAPAN

# INTRODUCTION

Thank you for purchasing this product.  
Please read this manual carefully to ensure safe operation and a long service life.

## SAFETY PRECAUTIONS

To prevent malfunctions, personal injury, or potentially fatal accidents, be sure to observe all cautions indicated in this page, because they are important for Safety.  
We cannot accept responsibility for any damage or accidents that may occur if the Safety Precautions are not heeded.

## SAFETY SYMBOLS

The following safety symbols are used in the manuals for this unit.

Symbol	Meaning	Explanation
	General caution	Indicates an unspecified, general caution, warning, or danger.
	Electric shock	Indicates the potential for electric shock.
	Fire	Indicates the potential for fire.
	Explosion	Indicates the potential for explosion.
	Pinch	Indicates the potential for finger injury from pinching.

<b>CAUTIONS</b>		Danger of injury and property damage may be caused.			
	<b>Be sure to ground the unit.</b> Grounding prevents electric shock and noise.			<b>Do not allow metal or foreign objects to infiltrate.</b> A fire or malfunction may result.	
	<b>Use only the specified fuse.</b> Use of incorrect fuse may cause a fire or malfunction.			<b>Do not supply power when disassembled or broken.</b> Electric shock or malfunction may result.	
	<b>Supply only the specified voltage.</b> Supplying incorrect voltage may cause a fire or malfunction.			<b>Do not cover the unit while the power is on.</b> Heat will accumulate, causing the unit to deform. Fire may result.	
	<b>Do not overload an electrical outlet.</b> Overloaded circuits may cause a fire.			<b>Never carelessly put your hands in the pen moving area.</b> Personal injury or mechanical breakdown may result.	
  	<b>Do not expose to chemicals, moisture, or gas.</b> A leak or spark may cause a fire, electric shock, or malfunction.			<b>Never touch the metal of the input terminals.</b> Electric shock may result.	

## CAUTIONS

When the UNICORDER is brought out from Japan,

The UNICORDER is designed and manufactured to be used only in Japan.

The UNICORDER is subjected to the Foreign Exchange Control Order and Foreign Trade Control Act and is considered as one of strategic goods under control. Therefore, it is recommended that necessary application such as export permit be made to Japanese Government before the UNICORDER is brought out from Japan.

PANTOS reserves the right to change the specification of the UNICORDER without prior notice.

No part of this manual may be reproduced in any form or any means, without permission in writing from PANTOS.

This manual has been prepared carefully to cover every aspect of the UNICORDER. Whenever you find any mistake or insufficient explanation, please contact to your local agent.

PANTOS is not responsible at all for any effect caused or resulted from usage of the UNICORDER.

# CONTENTS

1. OUTLINE	1
2. OUTSTANDING FEATURES	1
3. SPECIFICATIONS	2
4. OPERATING PROCEDURE	4
4.1. External drawing	4
4.2. Name and function of each part	5
4.3. Preparation for recording (measurement)	8
4.4. Loading of recording paper	9
4.5. Mounting of recording pen	11
5. CAUTIONS ON USE	12
5.1. Recording pen	12
5.2. Ground terminal	12
5.3. Environment	12
5.4. Chart drive	12
5.5. Recording paper	12
5.6. Maximum input voltage	12
5.7. Connection of input signal line	13
6. MAINTENANCE	14
6.1. Oiling	14

## 1. OUTLINE

The U-212 recorder is a portable recorder that is designed to be easy to use, regardless of size and weight as well as location.

## 2. OUTSTANDING FEATURES

- (1) Effective recording width is practical as 120 mm.
- (2) Since the pulse motor is adopted for Chart drive, you can freely select the rich feed speed of 24 stages and 23 speeds. Since a crystal oscillator is used as the reference oscillator, a stable feeding speed can be obtained.
- (3) Superimposed type event markers are equipped as standard, so you can place marks at arbitrary positions on the recording line.
- (4) Since it has a calibration power supply, it is easy to check and calibrate full span voltage accuracy.
- (5) Reliability was further improved by adopting the pen configuration and the torque reduction circuit for protecting the motor when the pen wobbled out.

### 3. SPECIFICATIONS

Models	U-212(00)	
Number of channels *1	1	2
Measuring method	Automatic zero balancing DC-servo	
Writing width	120mm	
Pen speed *2	0.5sec or less	
Zero point	Right zero of the recording paper	
Zero set range	±100% from reference point	
Zero point check switch	Provided	
Measuring range	10/50/100/500mV, 1/5/10/50V (8 ranges)	
Fine adjust for measuring range *3	Provided	
Input method	Floating method	
Input impedance	1MΩ (Constant)	
Tolerable signal source resistance	Less than 10kΩ	
Linearity	±0.4%	
Dead band	±0.2%	
Accuracy *4	±0.6% (23°C)	
Errors between ranges	±0.4% (23°C)	
Chart speed *5	<p>(1) 10/15/20/30/40/60 mm/h, cm/h, mm/min, cm/min 24 steps and 23 speeds (10mm/min and 60cm/h are overlapping)</p> <p>(2) Chart drive by External signal (Option)</p> <ul style="list-style-type: none"> <li>• Chart speed 1mm/min at 1Hz, 600Hz max.</li> <li>• Input impedance 4.7kΩ or more</li> <li>• External signal source <ul style="list-style-type: none"> <li>Voltage High level +2V ~ +20V</li> <li>Low level +0.8V ~ -20V</li> <li>(Operable at TTL level)</li> </ul> </li> <li>Signal waveforms Pulse, sine wave, square wave, triangular wave, etc. (Pulse width 50 μsec or more)</li> </ul>	
Recording paper	No.12002Z40 (Length 16mm, right zero)	
Recording pens	Cartridge type fiber tip pen	
Ink colors	Channel A : Red	Channel A : Red Channel B : Green
Pen lift	Manually operated	

Calibration voltage	Voltage 50mV Accuracy $\pm 0.4\%$ (23°C) Temperature coefficient $\pm 0.007\%/^{\circ}\text{C}$ max.		
Torque reduction circuit *6	Provided		
Event marker	Superimposing Amplitude $+3.5 \pm 1$ graduation Time 0.2 ~ 0.4sec		
Environment	Temperature 0 ~ 45°C Humidity 45 ~ 85%		
Power supply	AC100V $\pm 10\%$ 50/60Hz		
Power consumption (TYP)	Balanced	Approx. 18VA	Approx. 19VA
	Max.	Approx. 23.6VA	Approx. 32.6VA
Insulation resistance	Power - Chassis(GND) 50M $\Omega$ or more (DC500V megger) Input terminal - Chassis(GND) 100M $\Omega$ or more (DC500V megger)		
Noise rejection *7	CMRR	DC 120dB or more AC(50/60Hz) 120dB or more	
	NMRR	AC(50/60Hz) 40dB or more	
Dielectric strength	Power - Chassis(GND) AC1000V for 1 minute Input terminal - Chassis(GND) AC 500V for 1 minute		
External dimensions *8	280(W) $\times$ 150(H) $\times$ 200(D) mm		
Mass	Approx. 4.6kg		Approx. 5.0kg
Accessories	Recording paper No.12002Z40 Recording pen NDA-5R for channel A(Red) NDK-18G (2ch specification only) for channel(Green) Power cable Power cable adaptor Fuse 1A ( $\phi 5.2 \times 20$ ) External feed plug (Option) Instruction manual		1 1 1 1 1 1 1 1

- \* 1 Let short recording pen be channel A and long recording pen be channel B.
- \* 2 Time required for traveling 99% of the input signal.
- \* 3 Each measurement range can be expanded up to 5 times. (Maximum input voltage in 50V range is MAX 200V)
- \* 4 Accuracy including linearity when measured with the highest sensitivity range.
- \* 5 Set the Chart drive changeover switch "CHART SELECT" on the rear panel to the "EXT" position and add an external signal to "EXT PULSE" of the external control terminal (Option).
- \* 6 Protect DC servo motor frequently when voltage exceeding the measurement range is applied frequently or for a long time.
- \* 7 Indicates the measurement value in the maximum sensitivity range.
- \* 8 Dimensions of protrusions are not included.

# 4. OPERATING PROCEDURE

## 4.1. External drawing

The appearance of this recorder is shown in Figure 4.1-1.

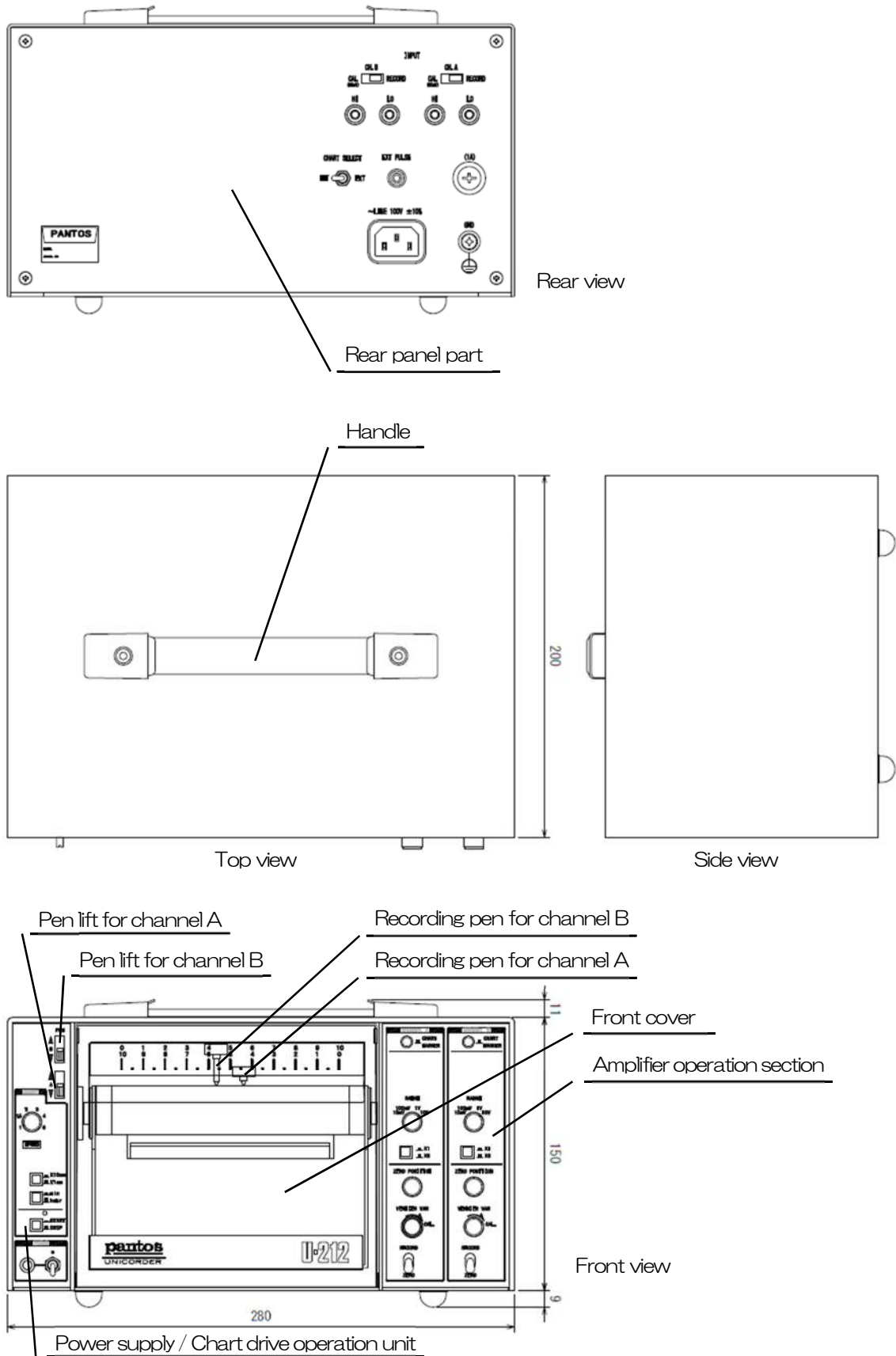

Fig.4.1-1 External drawing



4.2. Name and function of each part

4.2.1. Rear panel

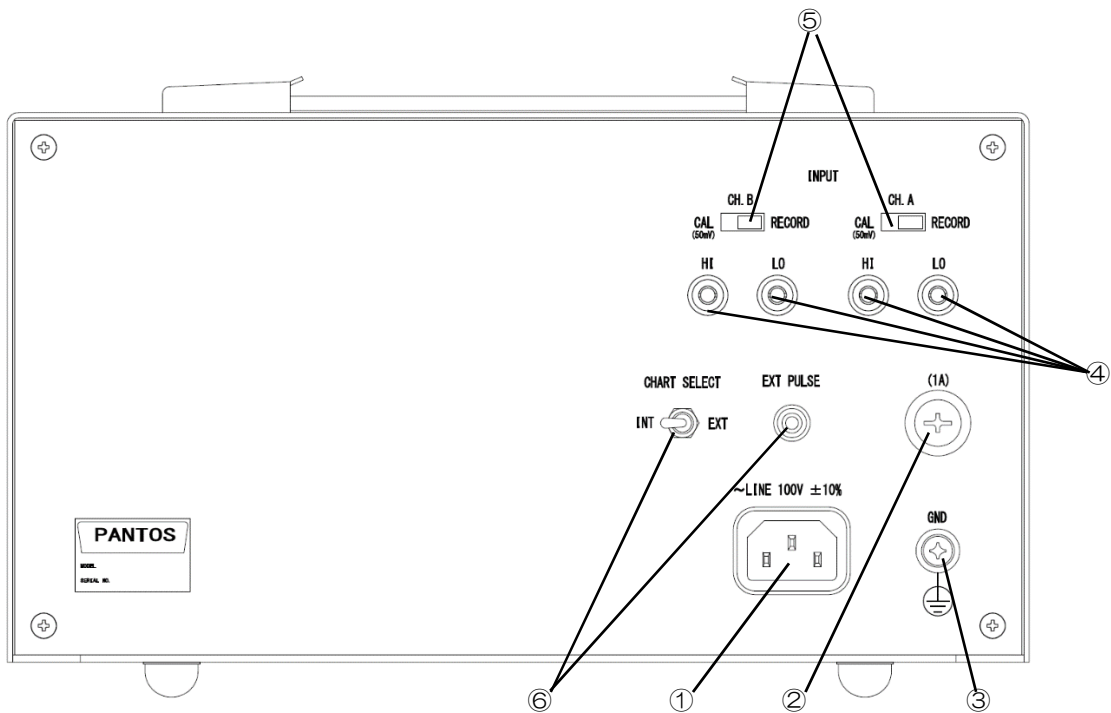

Fig.4.2-1 Rear panel

Part number	Name	Function overview
1	Power connector “~LINE 100V ±10%”	It is a connector for supplying power to the recorder. Connect the supplied power cord to this connector.
2	Fuse holder “FUSE” (1A)	There is a fuse to prevent recorder overcurrent accident. If the fuse blows out, please confirm that the recorder is normal and replace the fuse.
3	Ground terminal “GND”	The recorder is grounded to bring the chassis of the recorder and the ground to the same potential so that stable measurement can be carried out and it can also prevent electric shocks and the like. Be sure to ground it before use.
4	Input terminal “INPUT CH.A, CH.B”	This is the input terminal for the signal to be recorded. Connect the high impedance side to ground to the “HI” terminal and the low impedance side to the “LO” terminal.
5	Calibration switch “CAL/RECORD”	It is a changeover switch of the input signal. When set to “CAL”, the calibration voltage equivalent to the full span voltage at the 50mV range is applied and the full span accuracy can be confirmed. When set to “RECORD” side, input signal can be measured.
6	Chart drive by External signal (Option) “EXT PULSE, CHART SELECT”	Used to connect external pulse for external chart speed control. Set the Chart drive changeover switch “CHART SELECT” on the “EXT” position and add an external signal to “EXT PULSE” of the external control terminal

#### 4.2.2. Power supply, Chart drive operation unit

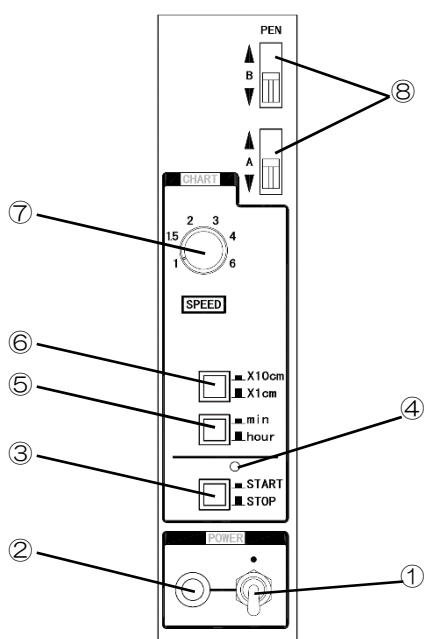
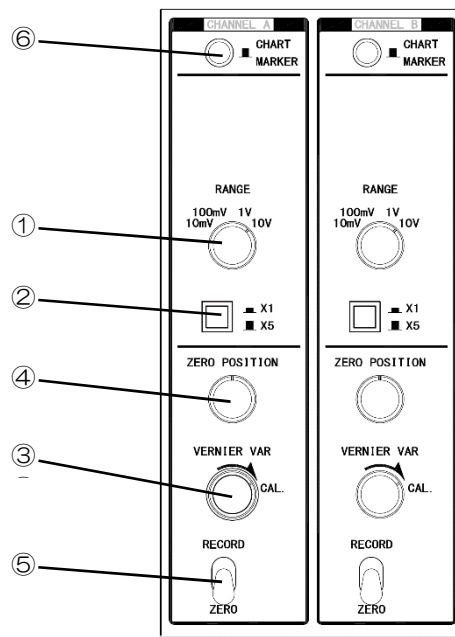

Fig.4.2-2

Part number	Name	Function overview
1	Power switch "POWER"	It opens and closes all recorder's power supply. When this switch is set to "ON", recorder operation becomes possible. (The "ON" of the power switch is indicated by ●)
2	Power supply pilot lamp	Lit when the power switch "POWER" is set to "ON".
3	Chart drive switch "CHART DRIVE"	The recording paper is sent out when "ON" (pressing the switch is pressed) with the switch that drives and stops the recording paper.
4	Chart drive pilot lamp	It turns on when the Chart drive switch "CHART DRIVE" is set to "ON".
5	Chart speed (minute or hour) changeover switch "min, hour"	This switch switches the unit of Chart drive speed (minutes, hours). It becomes the unit of min when the switch is pushed in.
6	Chart speed magnification changeover switch "x1cm, x10cm"	Switches the magnification (x 1, x 10) of the Chart drive speed. It becomes magnification of x 10 cm when the switch is pushed in.
7	Chart speed changeover switch "CHART SPEED"	The switch that sets the Chart drive speed, the value displayed represents the recording paper speed.
8	Pen lift lever "PEN LIFT"	By raising and lowering this lever, the recording pen moves up and down.

4.2.3. Amplifier operation section



In 1 channel specification, parts on CHANNEL B side are omitted.

Fig.4.2-2

Part number	Name	Function overview
1	Measurement range selector switch "RANGE"	It is set according to the magnitude of the input voltage with the voltage divider of the input signal.
2	Measurement range magnification selection switch "×1, ×5"	
3	Measurement range fine adjustment device "VERNIER VAR"	Each measurement range of the measurement range changeover switch can be enlarged up to 2.5 times, and the range between each range can be adjusted to an arbitrary measurement range and the input signal can be recorded with necessary amplitude. Each measurement range is the value when turning it to this knob "CAL".
4	Zero point adjuster "ZERO POSITION"	It is for setting the zero position of the recording pen, and when turned in the clockwise direction the recording pen moves to the right.
5	Zero point check switch "RECORD-CHECK"	It is ON / OFF switch of the input signal. When set to "CHECK", the zero point of the recording pen can be confirmed irrespective of the input signal. When set to "RECORD" side, input signal can be measured.
6	Event marker switch "CHART MARKER"	If you press this switch during recording, you can insert a mark superimposed on the recording pen.

#### 4.3. Preparation for recording (measurement)

Before using, please make the preparation in accordance with the following order.

(1) Set each operation unit as follows.

- Power switch ----- Set to "OFF"  
"POWER"
- Chart drive switch ----- Set to "OFF"  
"CHART DRIVE"
- Recording paper speed change switch ----- Set to the desired speed  
"CHART SPEED"  
Recording paper speed magnification changeover switch  
"×1cm, ×10cm"
- Recording sheet speed, time change switch ----- Set as desired unit  
"min, hour"
- Pen lift lever ----- Set to raised state  
"PEN LIFT"
- Zero point check switch ----- Set to "CHECK"  
"RECORD-CHECK"
- Measurement range selector switch ----- Set as desired range  
"RANGE"  
Measurement range magnification selection switch  
"×1mV, ×0.1mV"

(2) Ground the ground terminal "GND".

(3) After connecting the power cord to the recorder, connect it to the power supply.

(4) Load recording paper.

(5) Attach the recording pen to the pen holder.

(6) Connect the input signal line to the input terminal "INPUT" on the back of the recorder.

(7) Set the power switch "POWER" to "ON".

(8) Pen lift lever "PEN LIFT" to lower the recording pen on the recording paper.

(9) Set the zero position of the recording pen with the zero point adjuster "ZERO POSITION" of the amplifier operation section.

(10) Set the Chart drive switch "CHART DRIVE" to "ON" and send the recording paper.

(11) Set the zero point check switch on the amplifier operation section to "CHART MARKER" side.

The recording (measurement) preparation is completed with the above.

For measurement requiring high accuracy, start measurement after energizing for at least 30 minutes.

#### 4.4. Loading of recording paper

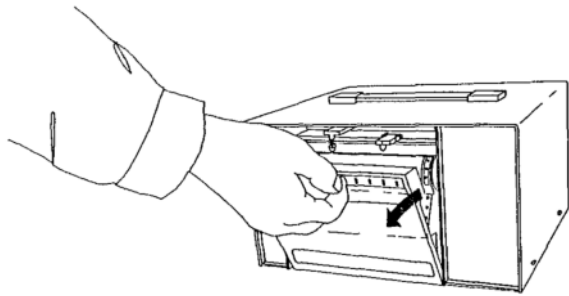

① Open the front cover

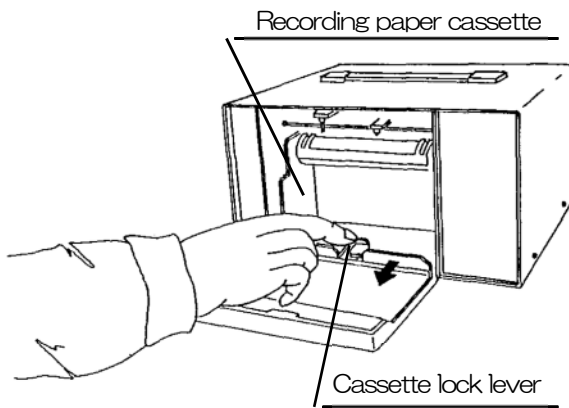

② Rotate the cassette forward

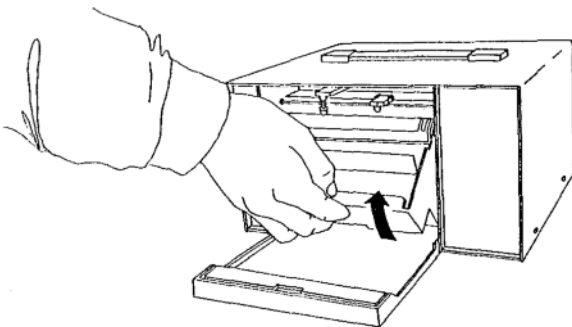

③ Rotate 90°

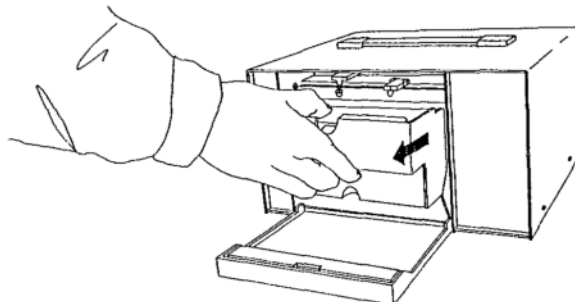

④ Pull forward



⑤ I will judge the recording paper

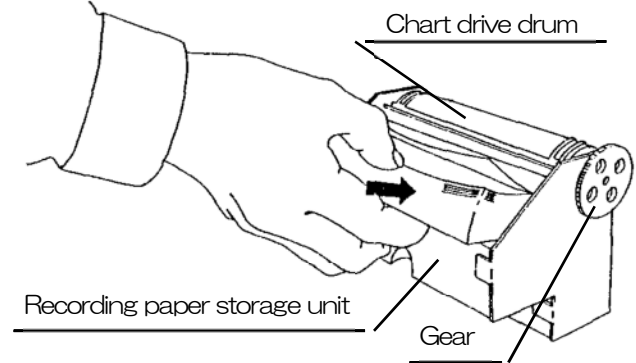

⑥ Place the recording paper so that the long hole of the recording paper comes to the side of the gear.

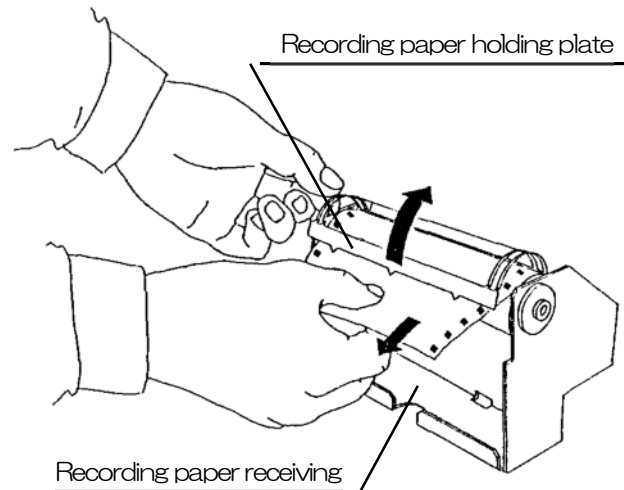

⑦ Fold the drawn out recording paper 2 to 3 and place it on the recording paper tray.

Figure 4.4-1

Please load the recording paper in the following order. (Figure 4.4-1)

- (1) Lift the pen with the pen lift lever.
- (2) Open the front cover. ----- ①
- (3) While pressing the cassette lock / lever, rotate the recording paper cassette slightly toward you. ----- ②
- (4) Remove the recording paper cassette in the order of ③ and ④.
- (5) Fold the recording paper. ----- ⑤  
(If you load the recording paper without discouraging it, folds may overlap and be fed out.)
- (6) Place the recording paper so that the long hole side of the recording paper perforation is in the recording paper compartment so that it comes to the side with the gear. ----- ⑥
- (7) Pass the leading edge of the recording paper between the Chart drive drum and the recording paper presser plate.
- (8) Fit the perforations on the left and right of the recording paper so that there is no forward and backward deviation in the sprocket of the Chart drive drum.
- (9) Fold the drawn out recording paper 2 or 3, fold it and place it on the recording paper receiver. ----- ⑦
- (10) Load the recording paper cassette in reverse order of (4).
- (11) Close the front cover.

The loading of the recording paper is completed with the above.

#### 4.5. Mounting of recording pen

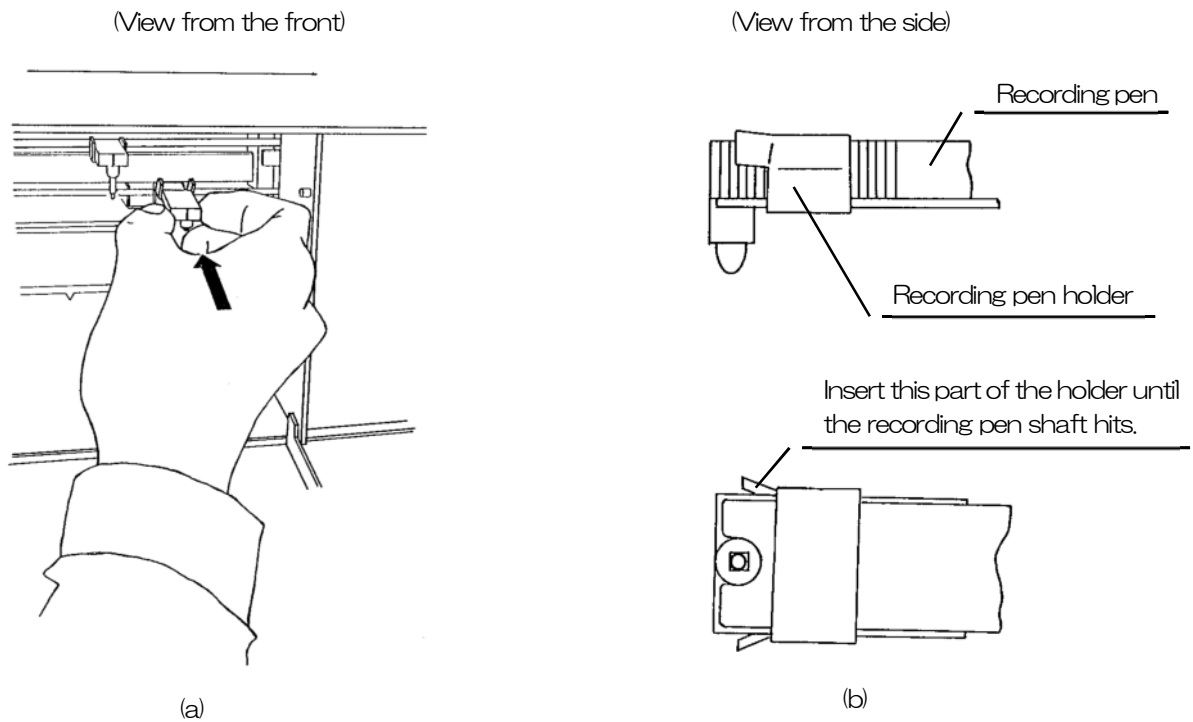

Figure 4.5-1

- (1) Open the front cover.
- (2) Remove the cap of the recording pen and insert the recording pen into the recording pen holder. (See Figure 4.5-1 (a))  
Please confirm that it is firmly attached. (See Figure 4.5-1 (b))

(Note) When not in use, be sure to cover the pen with a pen cap.

## 5. CAUTIONS ON USE

### 5.1. Recording pen

As the recording pen adopts a fiber chip, if you do not use it for a long time, if it leaves it, the ink may dry out at the pen tip and recording may not be possible. When not in use, please be sure to cover the recording pen with the cap provided.

### 5.2. Ground terminal

Be sure to ground it in order to obtain stable measurement results and to prevent electric shock.

### 5.3. Environment

Please use in temperature range 0 to 45 ° C and humidity range 30 to 85%.

Also, please use in an environment with as little vibration and dust as possible.

### 5.4. Chart drive

- Because the pulse motor is adopted as the Chart drive motor, step feed is felt at low speed feed. This step-like feed has a pitch that does not hinder the recording at all, so please use it with confidence.
- Immediately after inserting or removing the recording paper cassette or when recording paper is manually fed, recording paper may be delayed or temporarily stopped. This is due to a delay in the meshing of the gauge and is not abnormal.

### 5.5. Recording paper

- When using under high humidity (75% or more), the degree of folding may become unstable.
- Please use recording paper as much as possible.  
As reuse becomes more, the degree of folding becomes worse.
- When Chart drive is stopped for a long time, circular shape of the drum sticks to the recording paper, and the folding may become unstable.

### 5.6. Maximum input voltage

The input circuit of this recorder is provided with a protection circuit for excessive input voltage by zener diode, but fails if it exceeds allowable input voltage in Table 5.1. Please use the input voltage within the measurement range as much as possible.

Measurement range	Allowable input voltage range
10mV~500mV	Within 30V
1V~50V	Within 200V

Table 5.1



### 5.7. Connection of input signal line

Please use the shielded wire for the input signal line as shown in figure 5.1.

Also, in a use state where the signal line is long and the noise becomes a problem, we recommend using a double shield for the input signal line and grounding one end of the outer shield as shown in Fig. 5.2 I will.

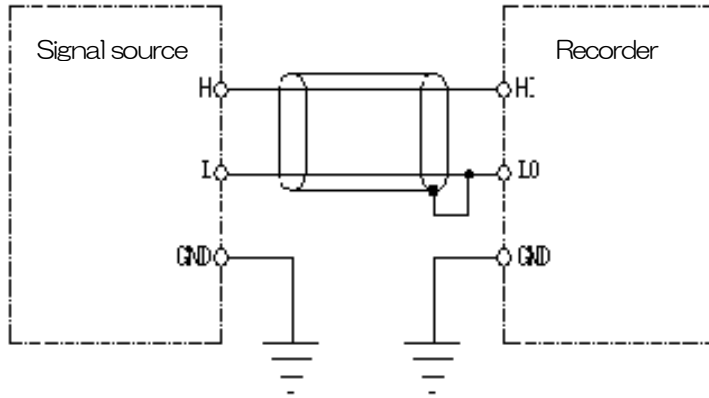

Note) Output terminals "H" and "L" of the signal source indicate "L" on the low impedance side and "H" on the high impedance side with respect to the ground.

Figure 5.1 Connection of signal lines (normal signal line connection method)

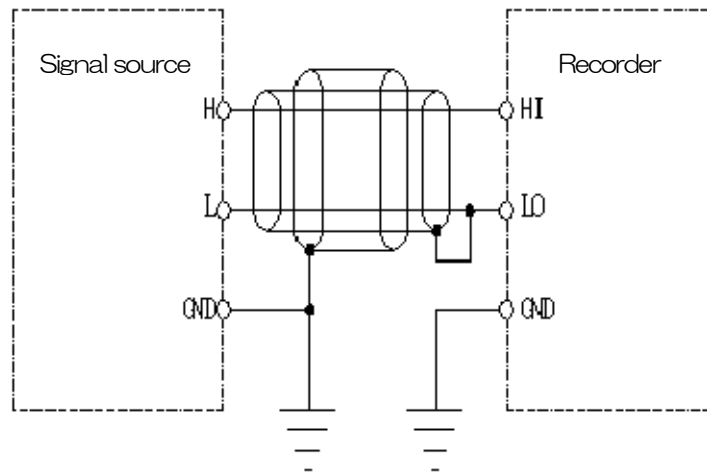

Figure 5.2 Connection of signal lines (Signal line connection method when noise becomes a problem)

## 6. MAINTENANCE

### 6.1. Oiling

In order to invariably keep the recorder in a good operating condition, a periodical oiling is essential. Oil the recorder one every 2 ~ 3 months. Drop one or two drips of refined machine oil. Oil generally over all moving sections. Be sure to wipe away any dust or foreign matter on the oiling point.

The oiling points are shown below.

- (1) Bearing portion of Chart drive drum
- (2) Gate rotating part of the Chart drive mechanism
- (3) Rail part of the pen (After wiping the trash, please apply a small amount of oil.)

However, please do not lubricate the electric part unnecessarily.

(Note) Please use sewing machine oil (spindle oil No. 1 or 2) for lubrication.

Specifications are subject to change without prior notice.